



## DESCRIPTION

### General

Brake light camera Universal\_CMOS HD\_1000 TVL\_170?\_IP68 (NTSC)

### Features

- HD CMOS
- Resolution 1280\*720 pixels (NTSC)
- 1000TV lines
- Ignition Power proof (+15)
- IP68 Waterproof
- Parking Guide lines (ON/OFF)
- Adjustable lens to change angle
- E-mark certification: E9-10R.05 16703 (printed in glass)
- CE-mark: EN 55022: 2010; EN 61000-3-2:2006+A1:2009+A2:2009; EN61000-3-3:2008; EN 55024:2010
- FCC-mark: ANSI C63.4-2003
- 2 Year warranty & Support

## EXCLUSIVE CAMERA FEATURES

### Adjustable head

Possible to adjust the camera lens.

**Angle Adjustable 30°**



### Parking Guide lines

It is possible to add or remove parking guide lines via the green loop wire



### Ignition Power proof (+15)

The kit include the power protection filter. In this way it is possible to connect the powersupply to an ignition feed (+15).

In this way you are able to watch the camera also in DRIVE gear or via manual selection.

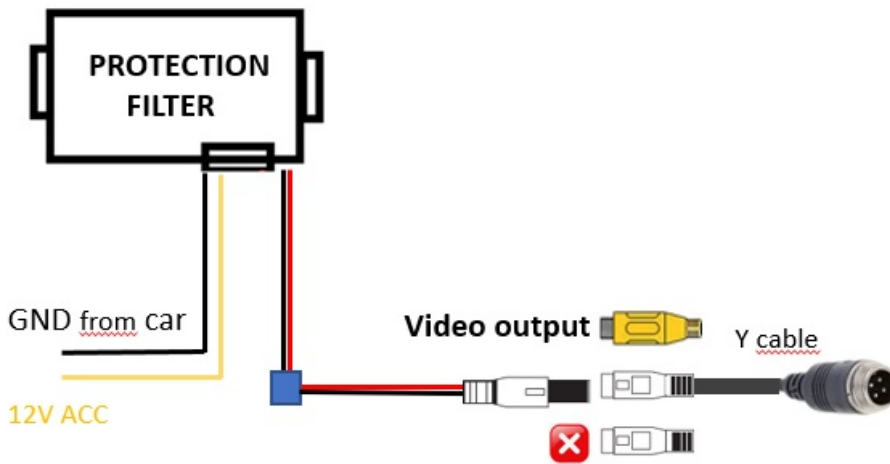

### NOTES

- We recommend that the installation will be performed by a qualified specialist
- Check also the other tabs for "Compatibility" - "Package contents" - "Product specifications"

### LEGAL NOTICE

Please check before purchase if it is aloud to install this camera and it wont affect your MOT.

## **COMPATIBILITY**

---

### **CAR**

This camera is univeral

### **NOTES**

---

- RCA output = female
- CVBS signal is NTSC